



# HOLY CROSS CHURCH

## REBUILD FUNDRAISING COMMITTEE

*Darin & Robin Blank ♦ Cheryl Colwell ♦ Taylor Hall*

*Tonya Hall ♦ Derek & Kasey Iffert ♦ Jason Warfel*

*Dear Parishioners,*

It has been almost eight months since the fire in our beloved church. Since that time the Rebuild Committee has been working with SERVPRO (damage restoration) and others to remove, clean up, and assess the damage inside our church. The Diocese of Belleville insurance will cover the damage, repair, and replacement of all items and building materials attributed to the fire, currently that estimated total is around \$1,200,000, with some items still pending. (attachment page 5)

Our current Holy Cross Church was constructed in 1930-1931. At various times over the church's 93-year history major repairs, renovations, and improvements have been undertaken. The Rebuild Committee views the fire as an opportunity to make some renovations and improvements to the church that meet the needs of our parish in our time.

The proposed improvements include:

- 1) **Adding an Interior Wall to Create a Gathering Space in the rear of the Church.** (page 1)
- 2) **Adding a Family Style Handicap-Accessible Bathroom in the rear of the Church.** (page 2)
- 3) **Updating Lighting, Sound System, and Safety Alarms. Adding a Handicap-Accessible Sanctuary Ramp. Refinishing: Doors, Stained Glass Windows, and Statues.** (page 3)
- 4) **[Phase 2] Adding a Breezeway/Carport on the West side of the Church.** (page 4)

The estimated cost for the proposed improvements comes to \$306,200. These improvements would need to be covered by the parish. Our church's building fund can provide up to \$150,000 of the proposed improvement cost with the remaining \$156,200 needing to be raised. (attachment page 6)

At various times over the 153-year history of our parish, the parishioners have been called upon to undertake substantial projects related to our church. From the building of the initial church in 1871; the decade of fundraising to build the current church in 1931; new additions such as electricity (1940s), a new organ (1956), the first sound system (1960s), stained glass windows (1963), first air conditioners (1972), carpet in the aisles (1972), digital Chronobell system (1984); major exterior repairs in 1989; interior renovations in 1993; and exterior repairs and new roof (2010s); the parish has always met the challenge. The Rebuild Committee believes this is one of those crucial times in our church's history. We are presented with an opportunity to make substantial improvements to our church that will benefit our entire parish family.

**HOLY CROSS WENDELIN**

5782 Ingraham Lane Newton, IL 62448 ♦ 618-752-5671 ♦ [holycrosswendelin.com](http://holycrosswendelin.com)

**THE FUNDRAISING COMMITTEE IS ASKING FOR YOUR HELP.** We are calling upon each family to make a minimum of two \$500 donations [\$1,000 in total] to the improvement project. The first \$500 donation [*asking before March 31, 2024*] would go towards the proposed 1-3 projects which will be completed simultaneously along with the fire repairs. The second \$500 donation [*asking before March 31, 2025*] would go towards the Breezeway/Carport which would be in the second phase of improvements once everything else was completed. If you have the means and are able, we encourage a donation in excess of the asking amount. We also understand that some families may not be able to give the full amount and any donation would be appreciated. All donations made to this cause will go directly to the improvement fund. Donations in excess of our goal will go towards additional upgrades and replenishing the church's building fund. Donations will need to be made out to "**Holy Cross Building Fund**" and please specify in the memo line "**Improvement Project**". Donations can be mailed to: **Holy Cross 5782 Ingraham Lane Newton, IL 62448**, or dropped in the collection at church. You can also donate online securely through the Holy Cross Church website [www.holycrosswendelin.com](http://www.holycrosswendelin.com) or QR Code.

Please find additional information on the proposed improvements attached. The information along with a video, and online donation form is available on the Holy Cross website. If you have any questions, we invite you to reach out to members of our fundraising committee or members of the rebuild committee.

This is our opportunity to make significant improvements to our beautiful church that will last for many generations to come. Thank you in advance for your generosity!



Donation QR Code

## *Holy Cross Rebuild Fundraising Committee*

### **REBUILD COMMITTEE**

Father Steven Beatty ... 618-697-2632  
 Cindy Blank ..... 618-843-8018  
 Keith Blank ..... 618-783-9330  
 Pam Blank ..... 618-783-9330  
 Sharon Edwards ..... 217-994-3267  
 Kelly Geier ..... 618-843-5794  
 Sherry Geier ..... 618-843-5795  
 Garrett Hall ..... 618-554-5821  
 Taylor Hall ..... 217-663-8520  
 Michael Kuenstler ..... 618-752-7103  
 Rhonda Kuenstler ..... 618-752-7103  
 Brad Rudolphi ..... 618-783-1080  
 Cathy Rudolphi ..... 618-562-8307  
 Travis Weber ..... 618-322-2726

### **FUNDRAISING COMMITTEE**

Father Steven Beatty ..... 618-697-2632  
 Darin Blank ..... 618-354-1511  
 Robin Blank ..... 618-838-0777  
 Cheryl Colwell ..... 618-843-9335  
 Taylor Hall ..... 217-663-8520  
 Tonya Hall ..... 618-783-3405  
 Derek Iffert ..... 618-559-3415  
 Kasey Iffert ..... 618-559-8061  
 Jason Warfel ..... 618-562-5822

**HOLY CROSS WENDELIN**

5782 Ingraham Lane Newton, IL 62448 ♦ 618-752-5671 ♦ [holycrosswendelin.com](http://holycrosswendelin.com)

# HOLY CROSS IMPROVEMENT # 1

## ADD WALL TO CREATE GATHERING SPACE

**ESTIMATED \$25,000 COST**

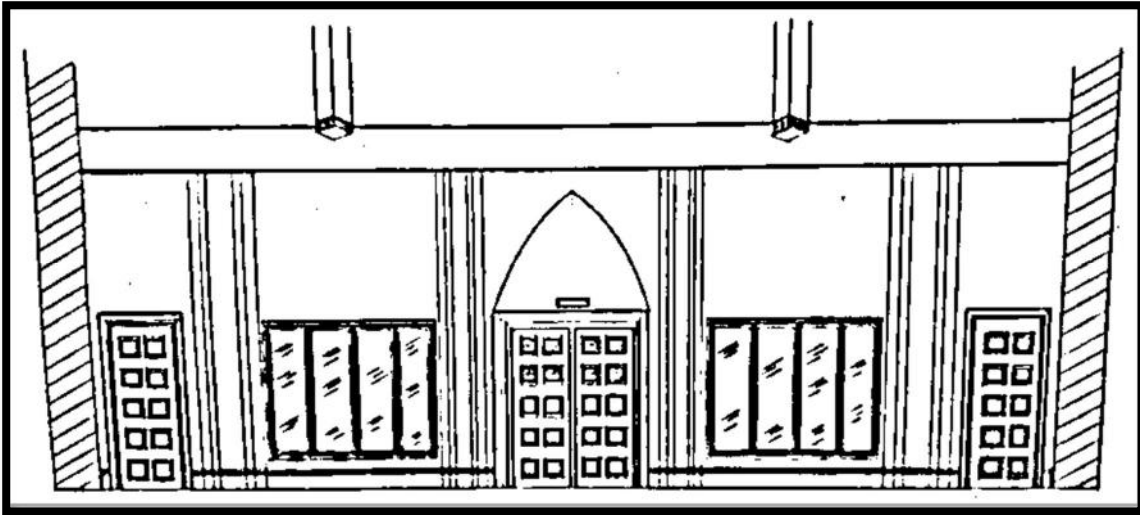

View from Inside Church Looking to Gathering Space

Proposal is to build a “new” back wall for the church utilizing the northmost pillars as part of the wall to create a gathering space. Existing interior doors will be re-purposed and brought forward to be part of the new wall. The addition of this wall would create a gathering space between the vestibule (north entrance) and the main church space by building a wall as pictured to the (right).

Above and below are renderings of what the space would look like. The picture (above) is of the wall looking from inside the church looking North towards the entrance. The picture below on the (left) is of the wall looking from inside the gathering space.

Proposed “New” Back Wall for Church

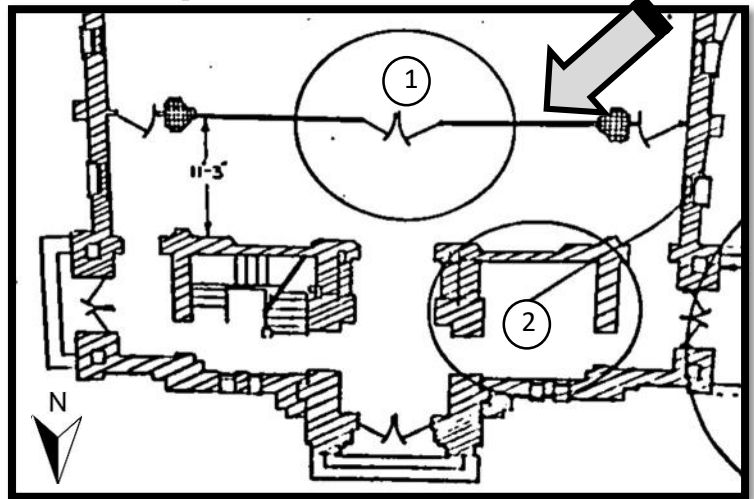

**WHY?**

- Fellowship Area (Meet/Greet) Before & After Mass.
- Provides additional indoor space in rear of church.
- Convenience and Accessibility. (Overflow seating)
- Ability to Sit/Stand in Gathering Space area and See/Participate in the Mass.

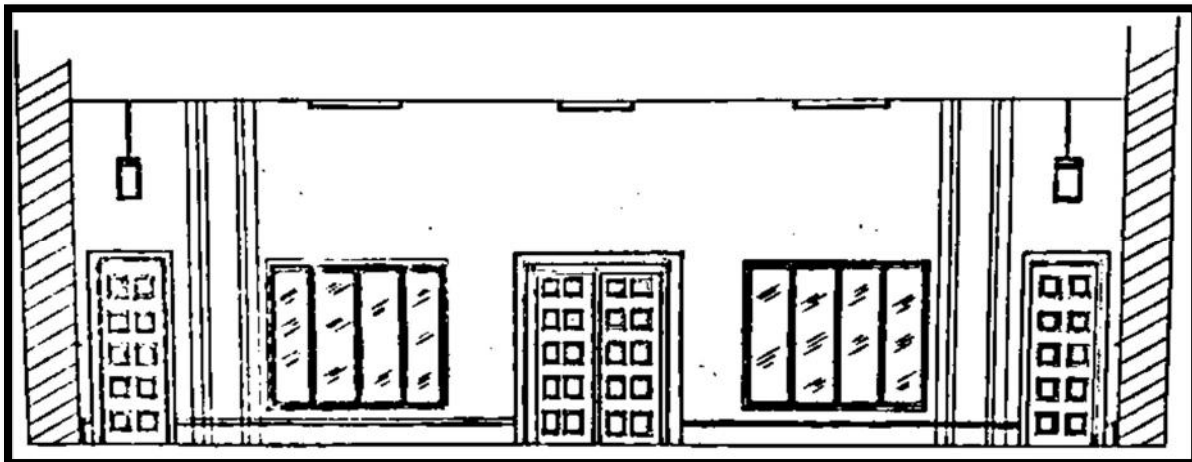

View from Inside the Gathering Space Looking into Church

**HOLY CROSS IMPROVEMENT #2**  
**ADD FAMILY STYLE BATHROOM**  
**ESTIMATED \$34,000 COST**



Proposal is to remove the west choir staircase and build a family style bathroom in the footprint of the old staircase.

**WHY?**

- Convenience and Accessibility (current restrooms attached to rectory are not handicap accessible.)
- Provide restroom for use during Masses, Weddings, Funerals.
- Easier to find for visitors to the church.
- Would limit the current hassle of going outside to access restrooms attached to rectory.

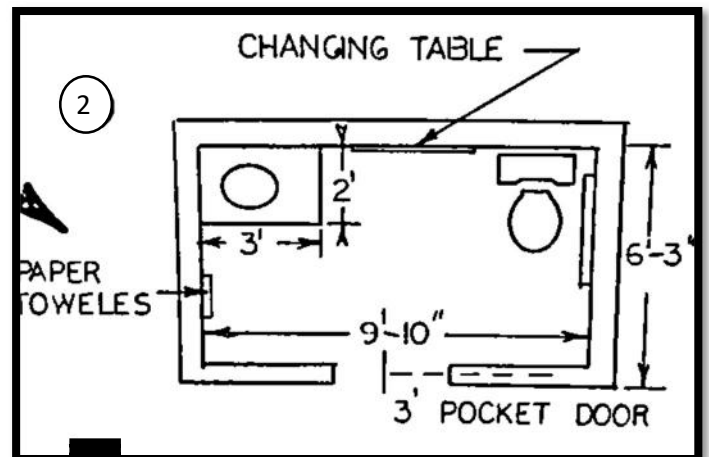

Proposed Family Style Restroom

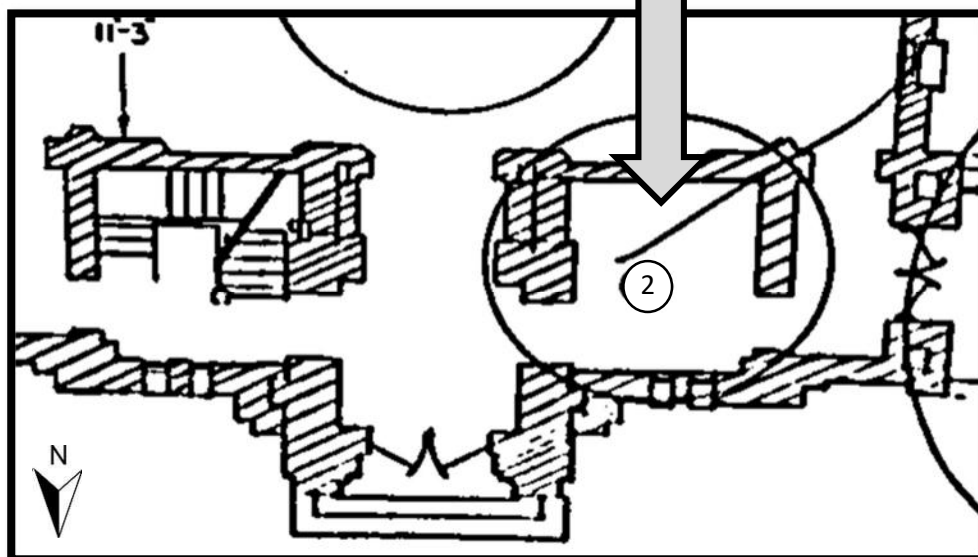

Proposal to Remove West Choir Staircase and Build Restroom

**HOLY CROSS IMPROVEMENT #3**

**UPGRADE: LIGHTING, SOUND SYSTEM, SAFETY ALARMS**  
**ADD HANDICAP-ACCESSIBLE SANCTUARY RAMP**  
**REFINISH: DOORS, STAINED GLASS WINDOWS, STATUES**  
**ESTIMATED \$150,000 COST**



*[ABOVE PHOTO IS AN ARTIST RENDERING AND IS NOT MEANT TO REPRESENT ANY FINAL OR APPROVED PLAN.]*

Proposal is to upgrade the Sound System and Acoustics; upgrade lighting; refinish interior and exterior doors; refinish statues in Church basement; stained glass windowpanes stripped and refinished; add automatic door openers on handicap accessible entrances; add fire, smoke, and CO2 alarms; add a 14' ramp to the sanctuary U-shaped (pictured below).

**WHY?**

- Highlight the Beauty of our Church.
- Provide better Acoustics and Engage Active Participation of Laity. *[Improve the Speaker Sound]*
- Address Needed Repairs of Doors, Windows, and Statues.
- Provide Safety Alarms (Fire/Smoke, CO2).
- Provide Handicap-Accessibility to the Sanctuary

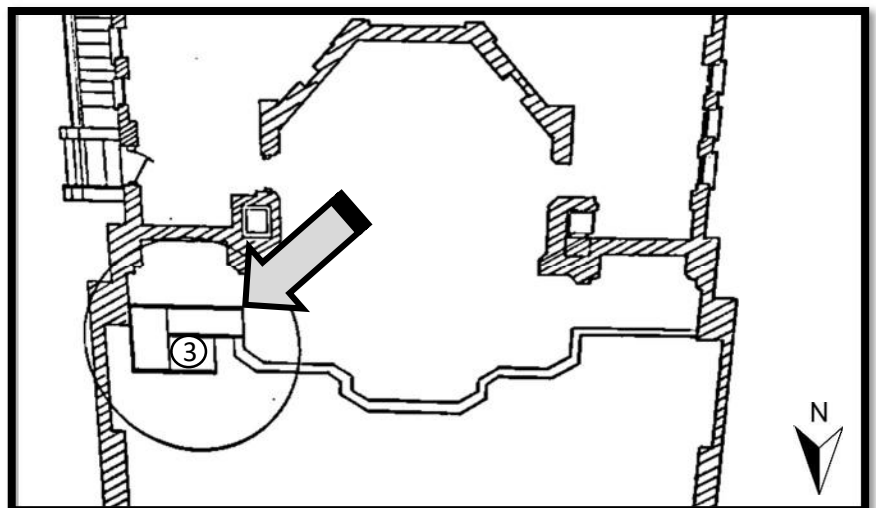

**Proposed 14' U-Shaped Ramp on Blessed Virgin Side to Sanctuary**

**HOLY CROSS IMPROVEMENT #4**

**ADD BREEZEWAY/CARPORT ON WEST SIDE OF CHURCH**

**ESTIMATED \$97,200 COST**

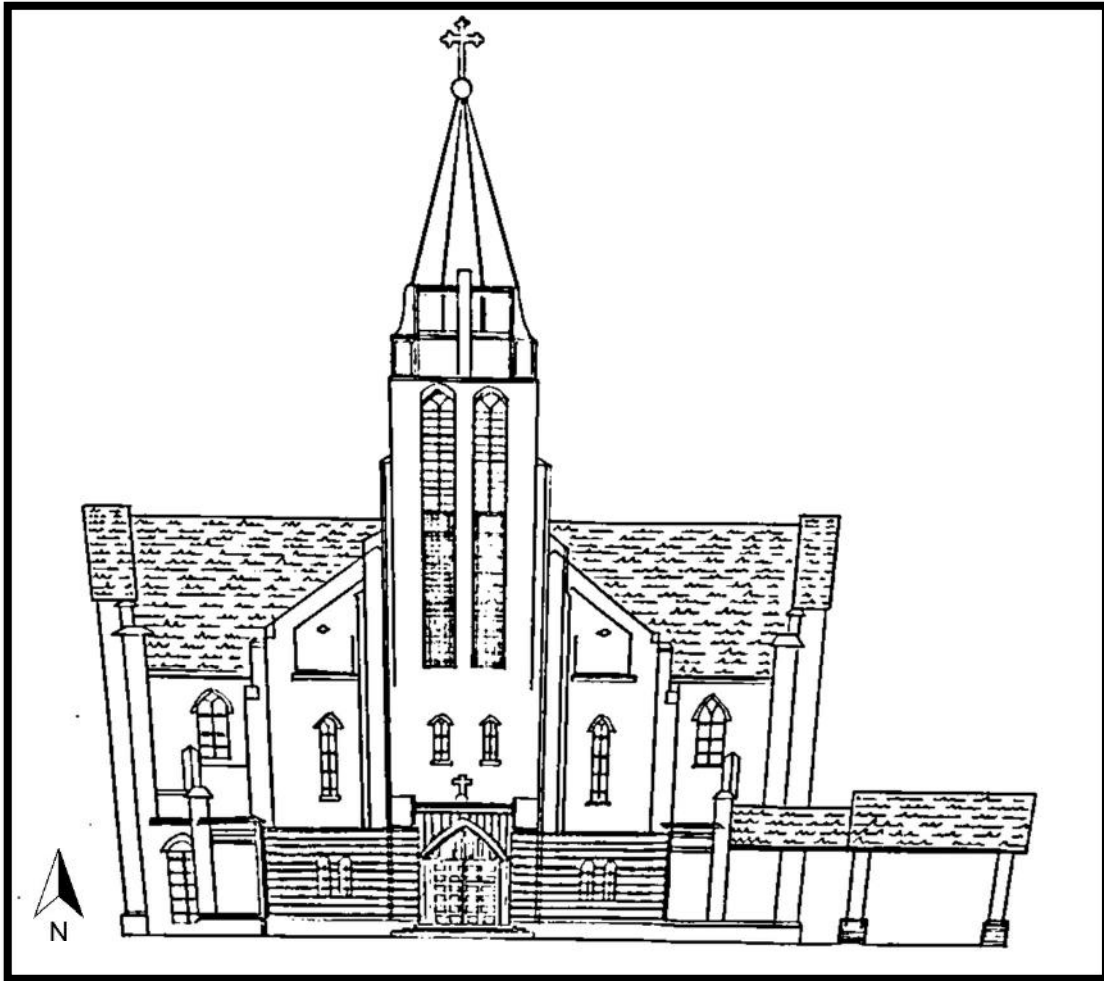

Proposal is to build a portico/carport on the west side of the Church. This would allow for covered access for elderly, special needs, funerals, and weddings. This improvement would be completed in the second phase of improvements after all other work has been completed.

**WHY?**

- Convenience and Accessibility
- Utilized as a Covered One-Level (no steps) Drop-Off for access into the Church.
- Covered access for the hearse during funerals and wedding car for weddings.

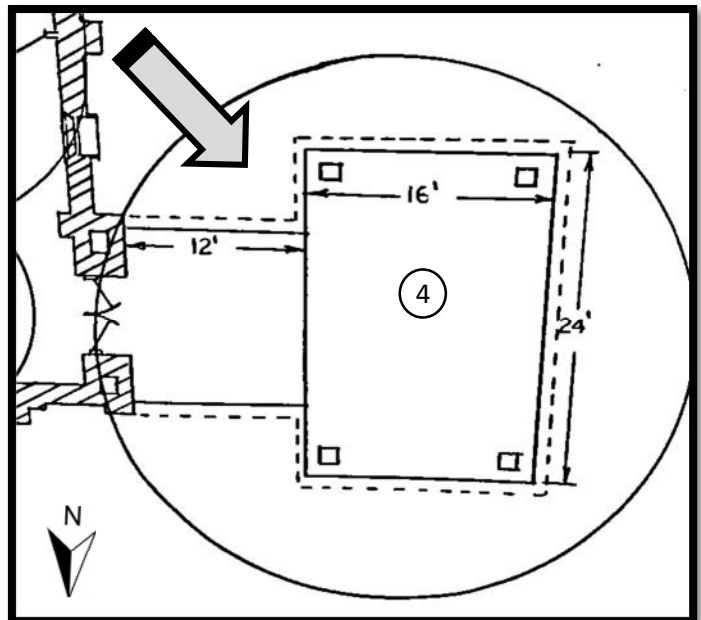



**Proposed Breezeway/Carport on West Side of Church**

## ITEMS COVERED BY INSURANCE

Work Description	Sub-Contractor	Bid Price	Price w/Servpro Markup	Status
Flooring, Subfloor, Windowsill, Chair Rail	AL-Thom Construction	\$216,412	\$259,694	Not Yet
Replace Burnt Lighting/Electrical	Pals Electric	\$174,832	\$209,799	Approved
Removal and Refinishing of Altars, Confessionals, and Reredos	Mobley Construction	\$150,000	\$180,000	Not Yet
Recommended Upgrades	Pals Electric	\$96,425	\$115,710	Approved
Refinishing of the Pews	Wood Renovators	\$82,635	\$99,162	Approved
Main Auditorium – Provide and install 2 115,000 BTU Furnaces, 2 – 5 ton AC Units, 2 – 5 Ton Coils	Zimdars A/C	\$45,182	\$54,219	Approved
Change Order to modify Scaffold to Remove Altar	Global Scaffolding	\$30,046	\$36,056	Approved
Balcony	AL-Thom Construction	\$29,272	\$35,126	Approved
Remove, Furnish, and Install Tile Flooring	AL-Thom Construction	\$29,077	\$34,893	Approved
Generator	Sunbelt	\$21,640	\$25,968	Approved
Clean 46 Windows (Interior Only)	Jacksonville Glass	\$25,500	\$30,600	Not Approved
North Systems in Balcony Install 2 – 5 Ton 14 Seer AC Units	Zimdars A/C	\$20,318	\$24,382	Approved
Temporary Heat	Sunbelt	\$16,077	\$19,293	Approved
ChronoBells	FieldWorks	\$15,505	\$18,606	Approved
Replace Upper Nave Windows	Jacksonville Glass	\$14,700	\$17,640	Not Approved
Replace Insulation	Olmstead Brothers	\$11,250	\$13,500	Approved
South System 70,000 BTU Furnace	Zimdars A/C	\$10,223	\$12,25	Approved
Repairing the Stairwell to Original	AL-Thom Construction	\$7,960	\$9,552	Approved
North System 70,000 BTU Furnace	Zimdars A/C	\$5,574	\$6,689	Approved
Change Order to Reconstruct Scaffolding to Allow Access to Replace Vents	BrandSafeway	\$3,570	\$4,284	Approved
Encapsulate Smoke Damaged Wood	Crampton Painting & Drywall	\$3,000	\$3,600	Approved
Reredos, Statue Shelves, Confessionals	TBD	TBD	TBD	
Organ	TBD	TBD	N/A	
Plaster, Paint Design (Interior)	Conrad Schmitt	TBD	N/A	
<b>TOTALS</b>		<b>\$1,009,198</b>	<b>\$1,198,773</b>	

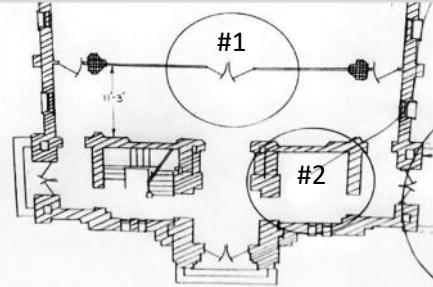
**PROPOSED HOLY CROSS IMPROVEMENTS**

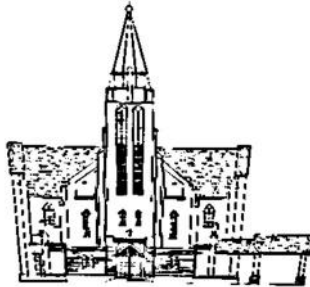
<p><b>IMPROVEMENT #1</b></p>  <p>Add Wall to Create Gathering Space</p>	<p>\$25,000</p>
<p><b>IMPROVEMENT #2</b></p> <p>Add Family Style Bathroom</p> 	<p>\$34,000</p>
<p><b>IMPROVEMENT #3</b></p>  <p>Upgrade Lighting, Sound System, Safety Alarms, Add Handicap Accessible Sanctuary Ramp, Refinish: Doors, Stained Glass Windows, Statues</p>	<p>\$150,000</p>
<p><b>IMPROVEMENT #4</b></p> <p>Add Breezeway/Carport on West Side of Church</p> 	<p>\$97,200</p>
<p><b>TOTAL OF IMPROVEMENTS</b></p>	<p><b>\$306,200</b></p>
<p>AMOUNT FROM BUILDING FUND</p>	<p>\$150,000</p>
<p><b>AMOUNT STILL NEEDED</b></p>	<p><b>\$156,200</b></p>